

# Word Template for an MeTrApp 2011 Paper

**E.-C. Lovasz and B. Corves**

<sup>1</sup>*“Politehnica” University of Timisoara, Romania, e-mail:  
erwin.lovasz@mec.upt.ro*

<sup>2</sup>*RWTH Aachen University, Germany, e-mail: corves@igm.rwth-aachen.de*

**Abstract.** MeTrApp 2011 conference aims to provide a special opportunity for the scientists to exchange their know-how and build up collaboration in the mechanism science field and its applications. Each submission will be rigorously reviewed. The Scientific Committee will choose the papers to be published in an edited book by Springer. The format of your paper is defined in this MS Word 2003 sample and contains the prescribed styles necessary to be published by Springer. These styles are opened from the Format menu by activating the “Styles and Formatting...” option. This sample is similar with MeTrApp 2011 Latex formatting (which is preferred over the Word). Your manuscript must be sent in Word 2003 format with figures attached in eps-format to [metrapp-2011@mec.upt.ro](mailto:metrapp-2011@mec.upt.ro). Please attach also a complete version in pdf-format for double-checking.

**Key words:** Please indicate four to five keywords, which will also be used for composing the Subject Index (written in 8 pt, justified).

## 1 Introduction

The manuscript should be written up to 8 pages and even number of pages. A manuscript of more than 8 pages will not be accepted. The font used in this Template is Times. Do not use other similar fonts.

Author names are written in 10 pt, Alignment left. Use *author* style for automatic formatting. Affiliation of authors is written in 10 pt, Alignment left. Use *Affiliation* style. Abstract is written in 8 pt, justified. Use *abstract* style.

The paper should contain an abstract, an introduction, a main text, conclusions, and references.

The title of the paper should be written in 16 pt bold, Alignment left. Use *title* style. Section titles are 14pt bold, alignment left and are *subtitle* style. Subsection titles are 14pt bold italic, alignment left and *subsubtitle* style. The following standard numbering is prescribed: 2, 2.1, 2.2 etc. Instead of simply listing headings of different levels we recommend to let every heading be followed by at least a short passage of text.

The following are some examples of a typical equation, figure, table, citations and references. Please do not change the proposed formatting by introducing other styles or by changing this template.

## 1.1 Paragraphs and indents

Please note that the first line of text that follows a heading is not indented (*first line style*), whereas the first lines of all subsequent paragraphs are (*normal style*). The text is 10 pt, justified. Spacing of the text is 12pt.

## 2 Equations

The same style as Normal text should be used in equation. Here, however Single space is recommended. Equations should be centered and numbered (*equation style*). Figure 1 presents the styles and sizes for equations. They should be referenced in the text as, for instance, (1). An example of equation is as follows

$$\mathbf{G} = \begin{pmatrix} 1 & 0 & 0 & 0 \\ a_i & 1 & 0 & 0 \\ 0 & 0 & \cos(\alpha_i) & -\sin(\alpha_i) \\ d_i & 0 & \sin(\alpha_i) & \cos(\alpha_i) \end{pmatrix}. \quad (1)$$

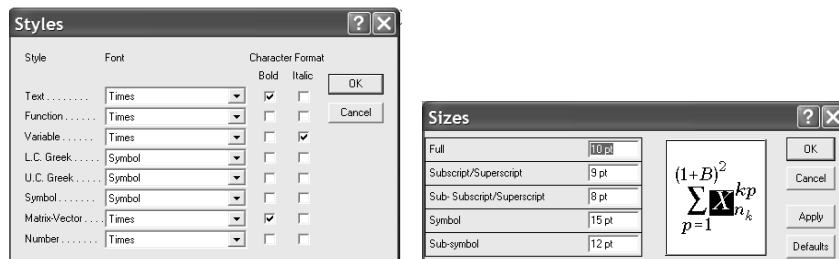
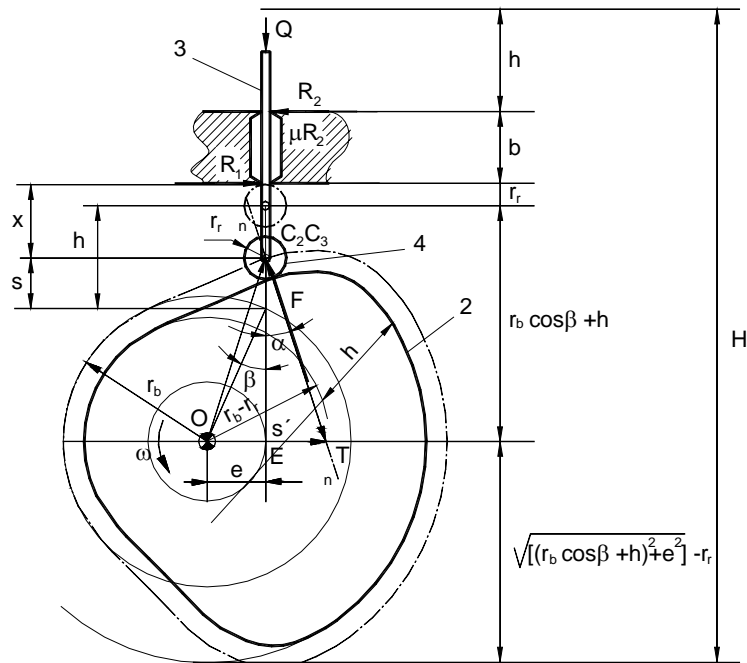

Fig. 1 Equation formatting.

## 3 Figures

Figures should be centered and referenced in the text as, for example, Figure 2. The font size in figures should be as Normal text (10 pt). Captions are placed under the figure, written in 8.5pt, using figlegend style. The example follows.



**Fig. 1.** The geometry, kinematics and forces equilibrium on a current position of a cam mechanism with roll translating follower

## 4 Tables

Tables should be centered and referenced in the text as, for example, Table 1. The font size in tables should be *table* style (8.5pt). Captions are placed before the table and are centered (*Tablelegend* style).

**Table 1.** Please write your table caption here.

<i>Description 1</i>	<i>Description 2</i>	<i>Description 3</i>	<i>Description 4</i>
Row 1, Col 1	Row 1, Col 2	Row 1, Col 3	Row 1, Col 4
Row 2, Col 1	Row 2, Col 2	Row 2, Col 3	Row 2, Col 4
Row 3, Col 1	Row 3, Col 2	Row 3, Col 3	Row 3, Col 4

## 5 Referencing

The reference list should be in an alphabetical order. A citation in the paper should have the form [1, 2, 3, 4] for a contribution in conference proceedings, monograph, journal article and on line document. Use *references* style (8.5 pt).

## 6 Conclusions

Your manuscript must be sent by e-mail to [metrapp-2011@mec.upt.ro](mailto:metrapp-2011@mec.upt.ro). Please respect the deadlines which are given on the MeTrApp 2011 webpage: <http://metrapp-2011.mec.upt.ro>

**Acknowledgments** The research work reported here was made possible by Grant No. 88 CEEX of Research Council. Use acknowledgement style.

## References

1. Ceccarelli, M.: The Challenges for Machine and Mechanism Design at the Beginning of the Third Millennium as Viewed from the Past. In: Proceedings of Brazilian Congress on Mechanical Engineering COBEM2001, Uberlandia, Invited Lecture, pp. 132-151 (2001).
2. Angeles J., Lopez-Cajun C.S.: Optimization of Cam Mechanisms. Kluwer Academic Publishers, Dordrecht, 1991.
3. Carra S., Garziera R., Pellegrini M.: Synthesis of cams with negative radius follower and evaluation of the pressure angle. Mech. Mach. Theory 39 (2004) 1017-1032.
4. Chan Y.W., Kok S.S.: Optimum cam design. Int. J. Comput. Appl. Technol. 9 (1) (1996) 34-47.
5. Husty, M. L. and Gosselin C.: On the singularity surface of planar 3-RPR parallel mechanisms. Mech. Based Design of Structures and Machines, 36, 411–425 (2008).
6. Porter, R.: Mechanism design for online real-time scheduling. In: Proc. of the ACM Conference on Electronic Commerce (EC'04) (2004) Available via CiteSeer. <http://citeseer.ist.psu.edu/article/porter04mechanism.html>